

CliniLever® Hospital Basin Set 150mm

Specification Data Sheet



Features

- Laminar flow nozzle to reduce the spread of Legionella supplied standard.
- Contra rotating handles to ensure ease of use.
- Smooth round design to facilitate easy cleaning and to help reduce dirt and bacterial growth.
- Supplied with a higher gooseneck outlet to facilitate easier hand washing for clinical staff which reduces the spread of bacteria within a healthcare environment.

To Specify

The AS/NZS 3718 WaterMark Approved CliniLever® Hospital Basin Set, complies to AS6400-2005 WELS rated to 4 Star and is supplied standard with a fixed gooseneck outlet and laminar flow nozzle, 150mm long lever handle finished in a bright chrome plate. 80mm long lever are available on request.

Code:

TCBHFJ150C - CliniLever® CP-BS Hospital Basin Set Fixed 150mm Levers and Jumper Valves



A family
owned
Australian
business



Performance Standards & Approvals

- AS/NZS 3718 – WaterMark
- WELS 4 Star Rating



Typical Dimensions

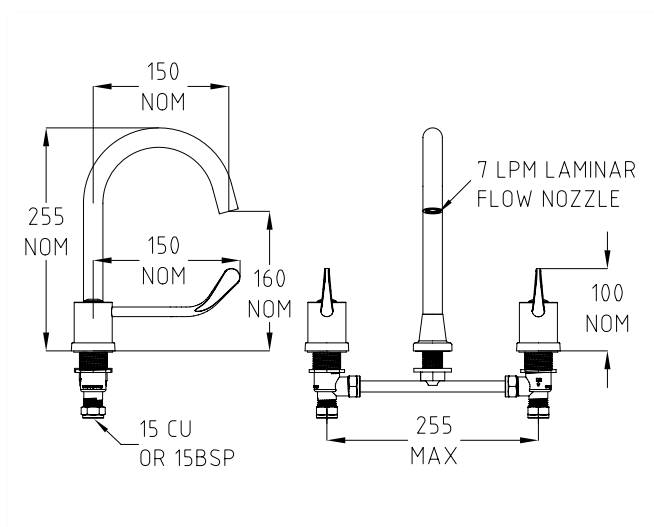

Technical Information

- Inlet: 1/2" CU/BSP
- Outlet: Laminar Flow
- Headwork: Jumper Valve
- Working Pressure Range (kPa): 50 Min - 500 Max
- Working Temperature Range (°C): 5 Min - 65 Max
- Nominal Flow Rate (LPM): 6.74
- Construction: Brass
- Finish: Chrome

Maintenance & Cleaning

Galvin Engineering products should be cleaned with a soft damp cloth using only mild liquid detergent or soap and water. Do not use cleaning agents containing a corrosive acid, scouring agent or solvents. Do not use cream cleaners, as they are abrasive. Use of unsuitable cleaning agents may damage the surface. Any damage caused in this way will not be covered by warranty.

Regular maintenance should be carried out in accordance with the installation and troubleshooting guides provided with the product, relevant Australian Standards, local authorities and state codes.

As part of maintaining a safe and reliable plumbing system, we recommend tapware and valves are operated on at least a daily basis.

Warranty

Galvin Engineering products are covered under our Manufacturer's Warranty at www.galvinengineering.com.au. Galvin Engineering products must be installed in accordance with the installation instructions and in accordance with AS3500 and the PCA, relevant Australian Standards and local authorities applicable to product being installed. Water and electrical supply conditions must also comply to the applicable national and/or state standards, failing to comply with these provisions may void the product warranty and affect performance of the product.

Whilst all reasonable care has been taken in compiling the information in this document, the designs, dimensions and products shown are indicative only and should not be relied upon without our prior approval. Due to our policy of continuous development, we reserve the right to alter any details of specifications or products without notice. All information, drawings, technical specifications and product designs remains the property of Galvin Engineering Pty Ltd.

Within Australia: **1300 514 074** Outside Australia: P: +61 (0)8 9338 2344
 F: +61 (0)8 9338 2340
 sales@galvinengineering.com.au
www.galvinengineering.com.au
 ABN: 78 008 719 382

GalvinEngineering 
 the mark of reliability

PERTH | SYDNEY | MELBOURNE | BRISBANE | ADELAIDE | UNITED STATES OF AMERICA | UNITED KINGDOM | NEW ZEALAND